

EN

TECHNICAL
MANUAL

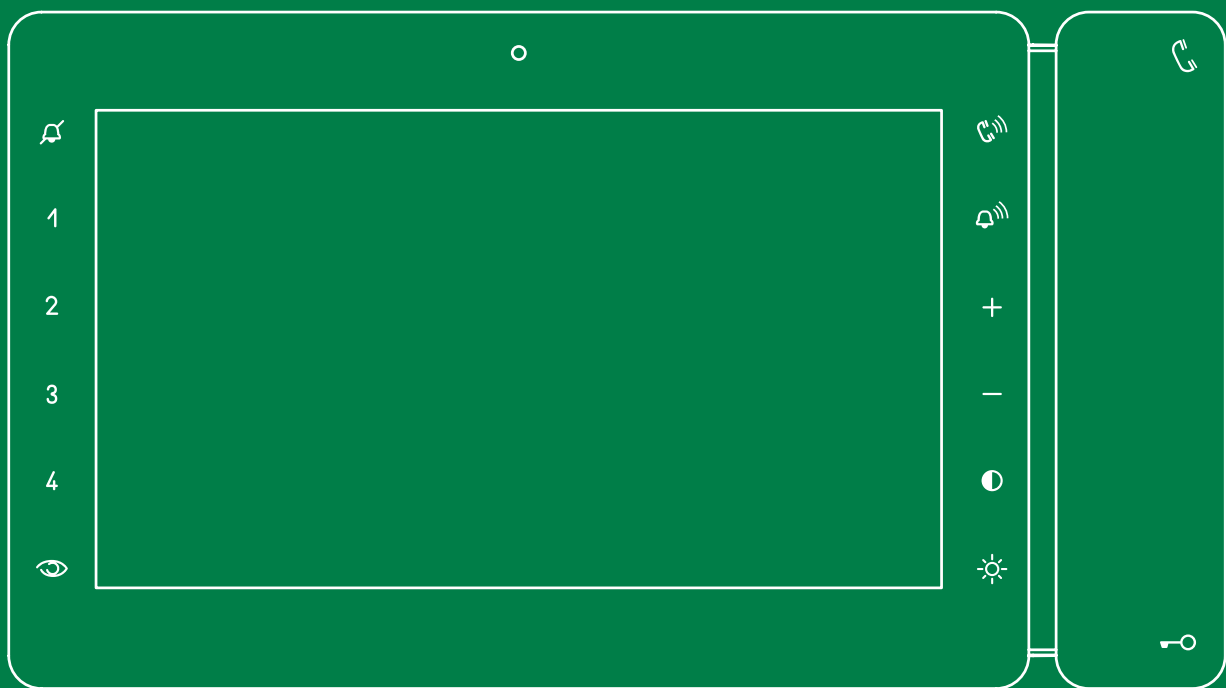

Maxi door entry monitor
Art. 6801W

 **Comelit**[®]
Passion. Technology. Design.

Table of contents

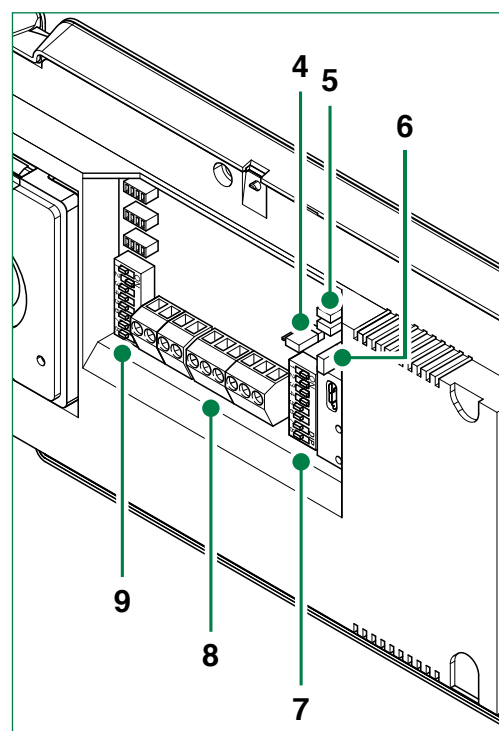
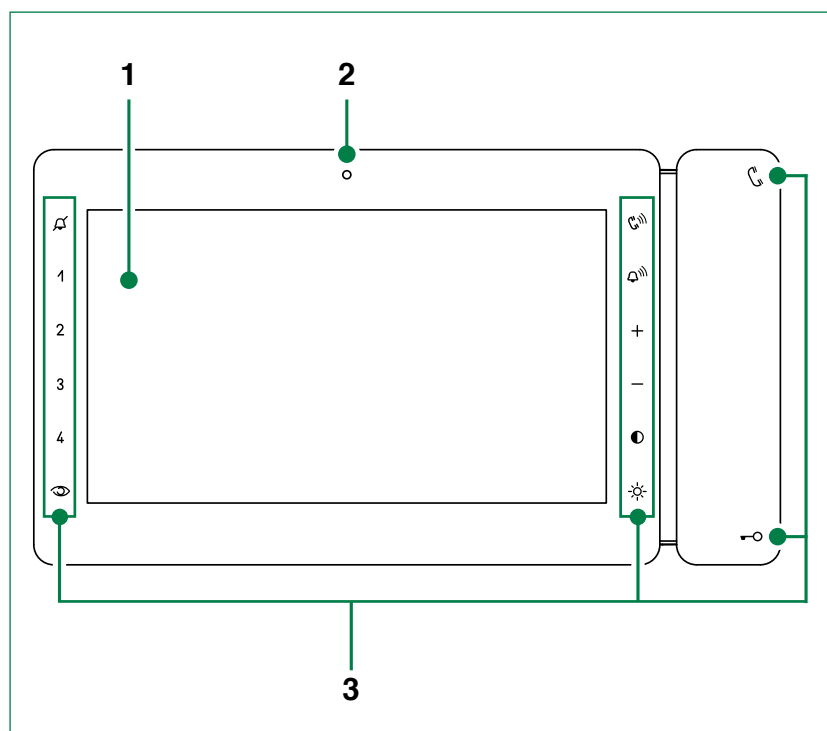

Table of contents	2
Description	3
Soft-touch key activation	4
Soft-touch key description	4
Indicator LED description	4
Technical specifications	5
Installation	7
Mounting the 7" MAXI SBC monitor on flush-mounted box Art. 6817	7
Wall-mounting (Art. 6820 - optional)	8
Connections	9
Variant: connection of call repetition device Art. 1122/A	9
Monitor configuration	10
Standard configuration for soft-touch keys	10
Activation/deactivation Doctor mode	10
Activation/deactivation Automatic Answer mode	10
Configuration of Main and Secondary internal units - DIP 8 of S2	11
Power supply configuration and management - DIP 7 of S2	11
Advanced monitor configuration	12
Warning	12
Programming for intercom call	12
Programming/deleting intercom address (selective intercom only)	
12	12
Programming buttons for intercom call	13
Direct programming of intercom call	14
Programming keys for generic or coded actuator	15
Programming buttons for other functions	16
Programming range	17
LED/alarm/lock-release/actuator programming	18
Changing monitor ringtones	19
Programming reset	19
System performance and layouts	19

Description

The Maxi series is comprised of hands-free monitors that can be used in “Building Kit” (exclusively 2-wire), Simplebus Top and Kit Video systems.

- Article 6801W is a colour monitor equipped as standard with 8 function buttons and 6 adjustment buttons.
- Article 6801W/BM is a colour monitor equipped as standard with 8 buttons, 6 adjustment buttons and an induction loop.



1. 7” colour LCD screen
2. Microphone
3. Soft-touch keys/Led
4. **CV6**
position A = contact IN1-IN2 > LED (default)
position B = contact CFP2-IN1 > ALARM/LOCK-RELEASE/ACTUATOR
5. **CV1 CV2** remove in case of separate power supply
6. **CV5** Jumper for video closure. In systems with more than one monitor connected in cascade, only the monitor furthest away must have CV5 closed.
7. **S2** Micro-switches for programming keys and functions
DIP 1-2-3-4 for key function programming
DIP 5-6 access to programming
DIP 7 for management of power supply voltage, see [“Power supply configuration and management”](#)
DIP 8 for main and secondary monitor setting, see [“Configuration of Main and Secondary internal units”](#)
8. Terminal block for system connection:
CFP1 CFP2 Outside door call input
S+ S- Terminals for additional ringtone output
IN1 IN2 Input terminals (programmable)
- + Power supply terminals
L L Bus line connection terminals
9. **S1** User code programming microswitches (see [addressing table](#))

Soft-touch key activation

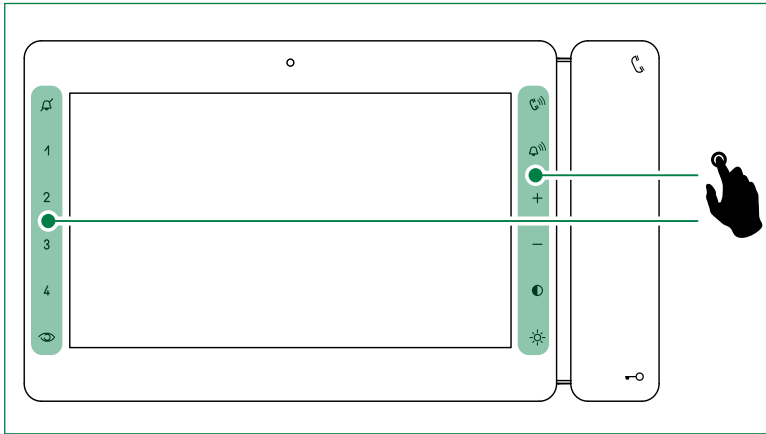

- ▶ Touch to activate the function keys
- ▶ Press the desired key once to activate the function associated with it



Wait for approximately 1 sec. before pressing the same key again. Pressing the same key several times in quick succession will cancel the command.

Soft-touch key description

- Audio key
- Lock-release key
- 1 2 3 4 Keys 1-2-3-4 (programmable)
- Self-ignition key (programmable)
- Privacy key
- Audio volume key
- Ringtone volume key
- + - Value 'Up/Down' key
- Contrast key
- Brightness key

Indicator LED description

- Audio LED
 - steady** = audio enabled/hands-free function
 - continuous flashing** = call received
- Lock-release LED
 - 1 flash** = confirm lock-release
 - 4 flashes** = programming successful
 - 10 flashes** = programming error
 - continuous flashing** = door open
- Privacy LED - Doctor
 - 4 flashes** = device engaged
 - slow flashing** = programming
 - 3 flashes (every 5 s.)** = Doctor function enabled
 - steady** = privacy function enabled



The monitor Art. 6801W is designed for use in colour systems, in the SB2 section downstream of Art. 4888C, or in systems without mixer, such as the system with 2-wire KIT or Art. 1210.

Technical specifications

MAIN SPECIFICATIONS		
	6801W	6801W/BM
Flush-mounted	Yes	Yes
Wall-mounted	Yes	Yes
Desk base-mounted	Yes	Yes
Hands-free function	Yes	Yes
Induction loop	-	Yes
Type of display	LCD	LCD
Display size (inches)	7" 16:9	7" 16:9
Display resolution (H x V)	800x480 pixel	800x480 pixel
B/W or colour display	Color	Color
Product colour	White RAL9003	White RAL9003
Sensitive Touch technology	Yes	Yes
Total buttons	8	8
LED signaling	14	14
COMPATIBILITY		
Simplebus Top audio/video system	Yes	Yes
Building Kit audio/video system	Yes	Yes
Kit audio/video system	Yes	Yes
FUNCTIONS		
Actuator control function	Yes	Yes
Self-ignition	Yes	Yes
Switchboard call function	Yes	Yes
Intercom function	Yes	Yes
Call forwarding	Yes	Yes
Privacy function	Yes	Yes
Redial	Yes	Yes
Floor door call function	Yes	Yes
Customisable ringtone	Yes	Yes
Alarm function	Yes	Yes
Sound diffusion control	Yes	Yes
Receiving text messages	Yes	Yes
Images reception	Yes	Yes
HARDWARE SPECIFICATIONS		
Removable terminals	Yes	Yes
SETTINGS		
Loudspeaker volume control	Yes	Yes
Microphone volume control	Yes	Yes
Ringtone volume control	Yes	Yes
Display brightness control	Yes	Yes
Display contrast control	Yes	Yes
Display colour control	Yes	Yes
GENERAL INFO		
Product height (mm)	124	124
Product width (mm)	223	223
Product depth (mm)	25	25

TECHNICAL SPECIFICATIONS	6801W	6801W/BM
Power supply voltage	22÷28Vdc	22÷28Vdc
Maximum current absorption (mA)	400	-
Power consumption stand-by (mA)	36	36
In called absorption (mA)	310	310
In communication absorption (mA)	400	400
Loudspeaker	80mm 80Ohm 1W	80mm 80Ohm 1W
Operating temperature (°C)	-5÷40	-5÷40
RH max operating humidity (%)	25 - 75 %	25 - 75 %
Clamps	CFP1 CFP2 IN1 IN2 S+ S-	CFP1 CFP2 IN1 IN2 S+ S-

Installation

Mounting the 7" MAXI SBC monitor on flush-mounted box Art. 6817

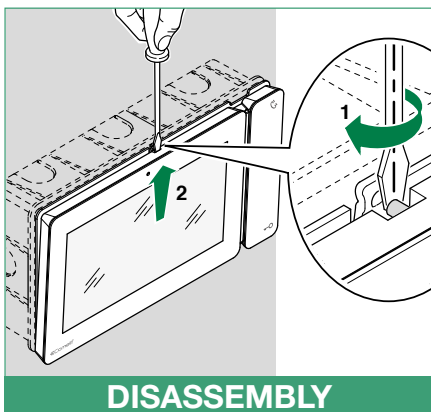
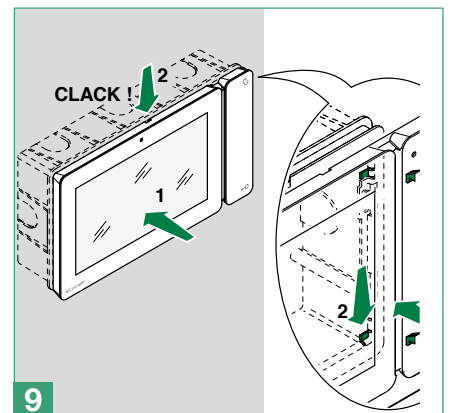
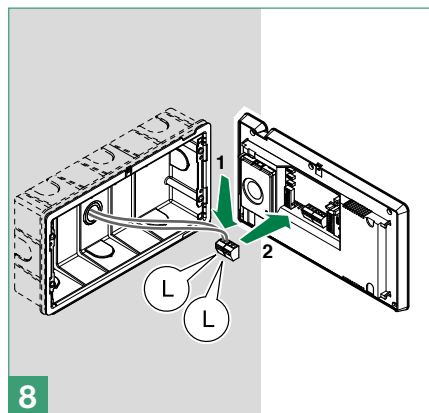
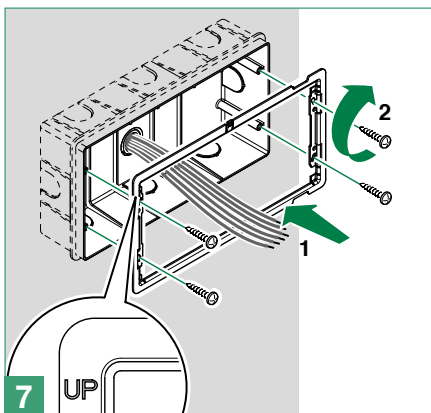
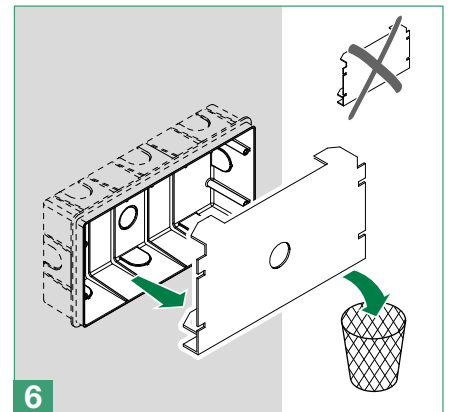
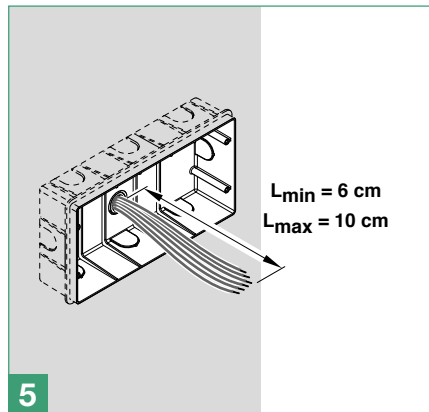
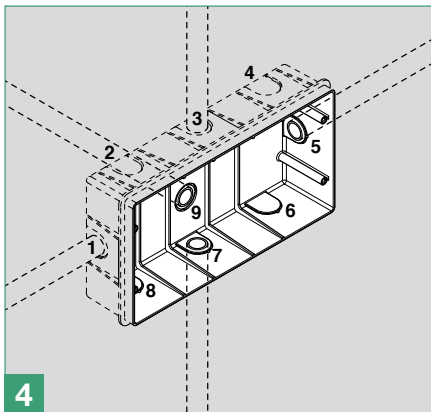
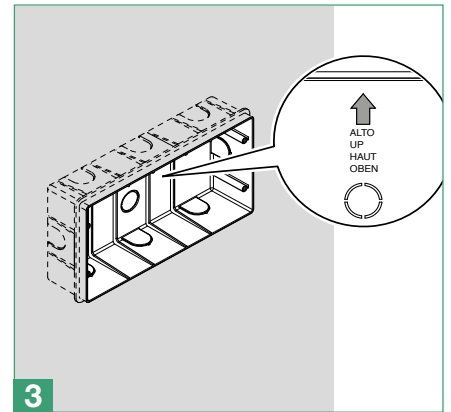
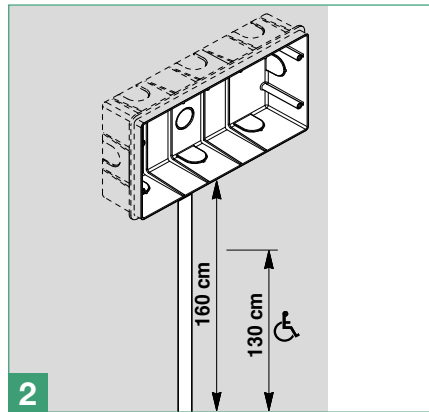
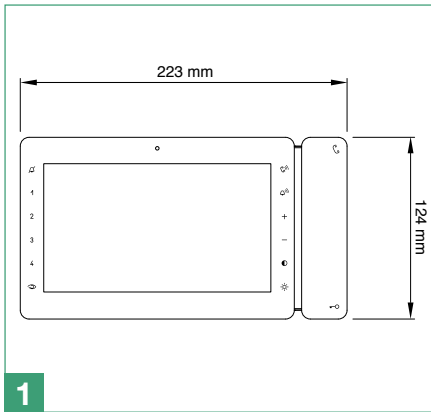

DISASSEMBLY

Wall-mounting (Art. 6820 - optional)

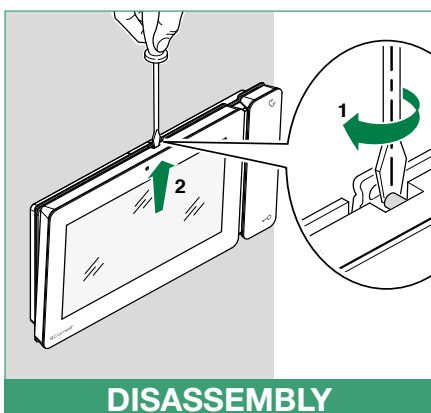
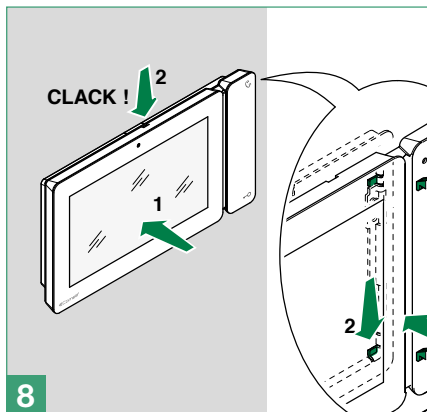
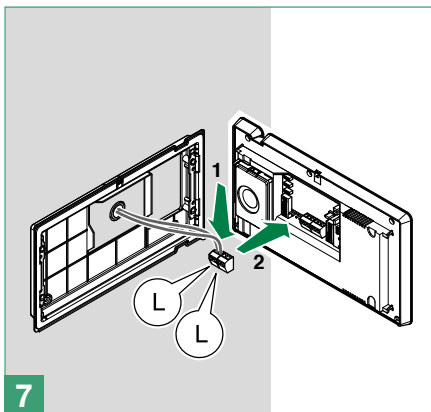
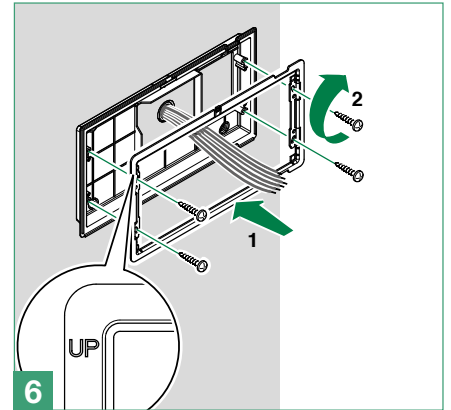
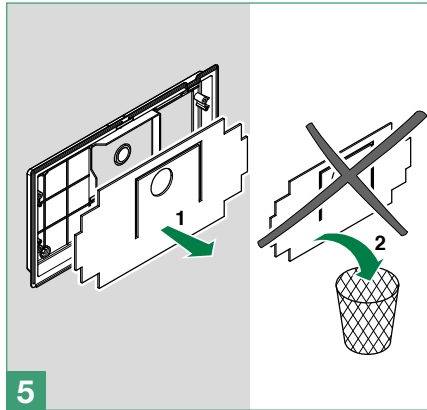
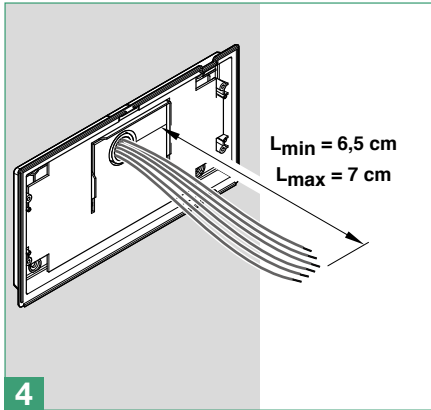
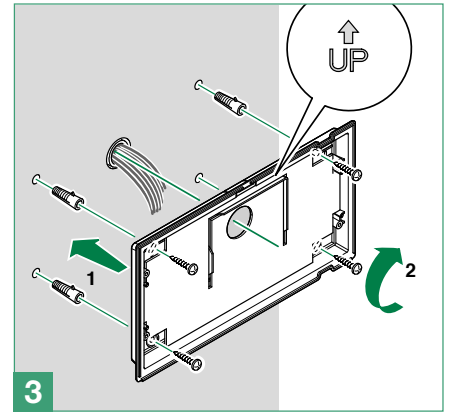
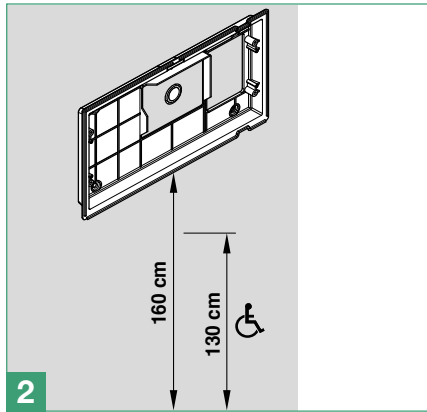
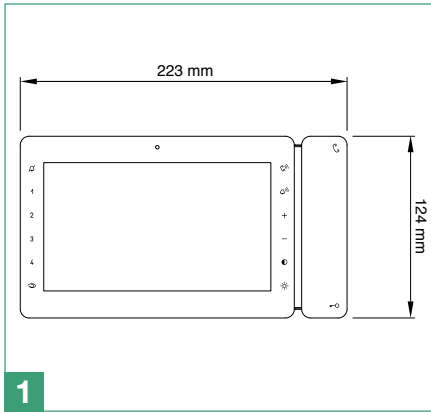

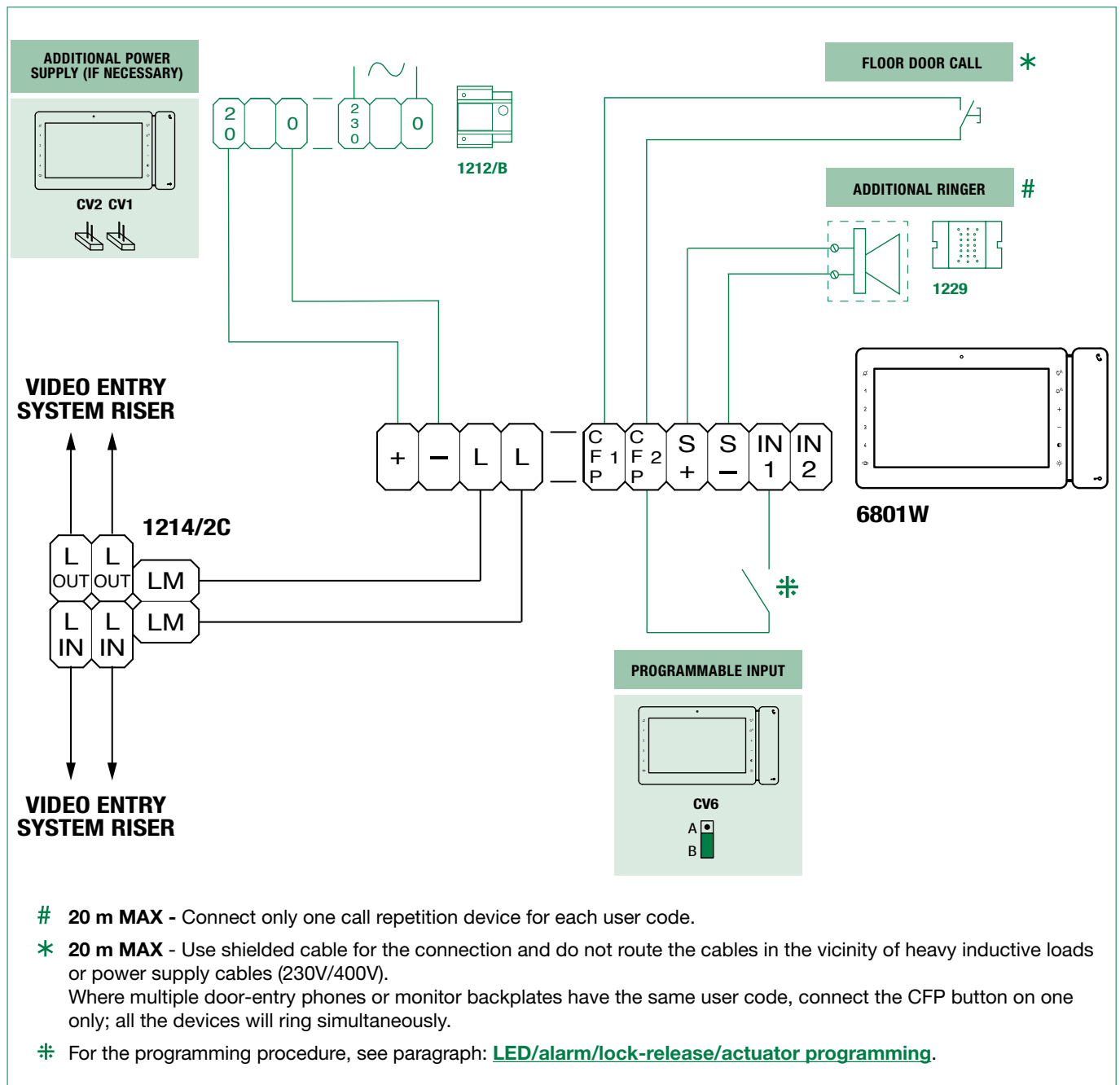

Connections

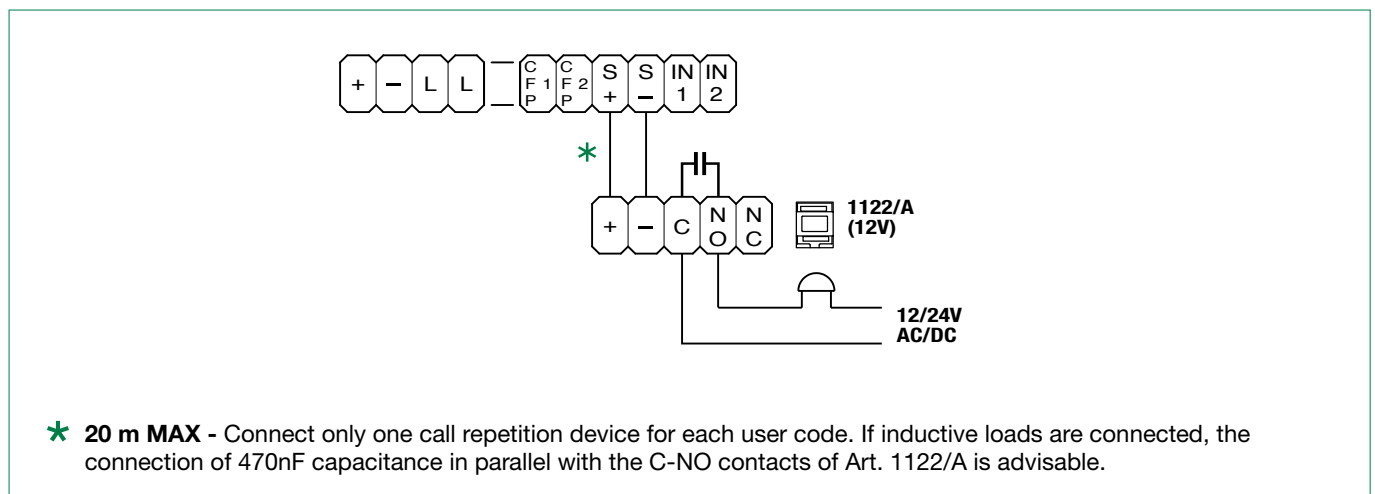

Variant: connection of call repetition device Art. 1122/A







Monitor configuration

Legend	
0	DIP-switch OFF
1	DIP-switch ON
	Lock- release
	Audio
ACT	Actuator
AI	Self-ignition **
CCP	Main switchboard call [not for use in systems with KIT]
CCS	Secondary switchboard call [not for use in systems with KIT]
K	Guardian doorentry phone call
D	Doctor
PAN	Panic [not for use in systems with KIT]
INT	General or selective programmable intercom [general internal call as standard for KIT and Simplebus Top]
INTb	Two-family intercom [for KIT only]
NULL	No function
PROG	Programmed functions, see " Advanced monitor configuration ". In this DIP switch setting, the buttons control the programmed functions; the NON-programmed buttons control functions referred to on line 0000 (default).



** Press and hold to enable/disable the function

Standard configuration for soft-touch keys



DIP-switch S2				Programmable functions						
DIP 1	DIP 2	DIP 3	DIP 4			1	2	3	4	
0	0	0	0			CCS	ACT	D	PAN	AI
1	0	0	0			ACT	INT	INTb	D	AI
0	1	0	0			INT	INTb	ACT	CCS	AI
1	1	0	0			ACT	CCP	PAN	K	CCS
0	0	1	0			ACT	ACT	ACT	ACT	ACT
1	0	1	0			INT	CCS	CCP	INTb	ACT
0	1	1	0			AI	K	CCS	CCP	D
1	1	1	0			INTb	AI	INT	PAN	INT
0	0	0	1		CCS	D	AI	INT	PAN	
1	0	0	1		K	PAN	CCP	AI	CCS	
0	1	0	1		CCP	PAN	ACT	INT	K	
1	1	0	1		PAN	CCS	K	ACT	CCP	
0	0	1	1		D	INT	ACT	AI	INTb	
1	0	1	1		INT	INT	INT	INT	INT	
0	1	1	1		INT	INT	INT	INT	INT	
1	1	1	1		NULL	NULL	NULL	NULL	NULL	NULL

Standard configuration for DIP switches 1-2-3-4 

Activation/deactivation Doctor mode

- ▶ Press and hold (4 s.) the programmed key (Default key 3)
 - » (ACTIVATION)  + 3 flashes every 5 s. 
 - » (DEACTIVATION) **BEEP**

Activation/deactivation Automatic Answer mode

- ▶ Press on the audio activation key  for 4sec
 - » (ACTIVATION)  + audio LED with FIXED ILLUMINATION
 - » (DEACTIVATION) **BEEP** + audio LED OFF

Configuration of Main and Secondary internal units - DIP 8 of S2

- ▶ To configure an internal unit as the main unit, set **DIP8** of **S2** to **OFF**.
- ▶ To configure an internal unit as a secondary unit, set **DIP8** of **S2** to **ON**.

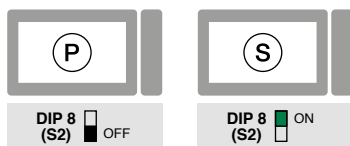

In systems with Art. 1209 or Art. 1210, you can configure a maximum of 1 main monitor (+ 3 separately powered) while in systems with Art. 4888C you can configure a maximum of 2 main monitors (+ 2 separately powered).

Power supply configuration and management - DIP 7 of S2

- ▶ For correct power management, the DIP switch should be set in accordance with the type of system and its configuration:
 - **in systems with power supply units 1209 and 1210:** always set the DIP switch to **ON**
 - **in systems with power supply unit 4888C:** for secondary internal units, always set the DIP switch to **OFF**, for main internal units, follow the indications given in the examples in the figure below:
 - 1 main internal unit,
 - 2 main internal units,
 - 3 main internal units of which 1 is powered separately.

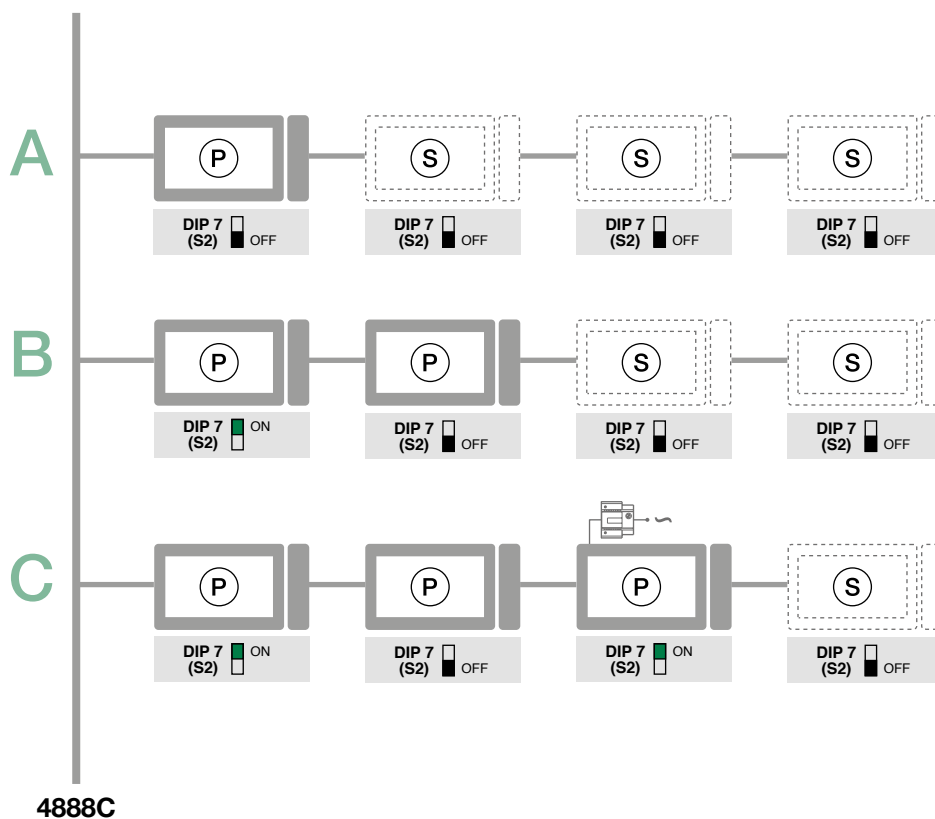

Advanced monitor configuration

Warning

If the default settings (see table [“Standard configuration for soft-touch keys”](#)) do not reflect requirements, the keys can be programmed differently by carrying out the steps below.
At the end, set S2 DIP switches 1-2-3-4 to the combination 1111 (PROG setting in the configuration tables ["Advanced monitor configuration"](#)). In this dip switch setting, the keys control the programmed functions; the NON-programmed keys control functions referred to on line 0000 (see table [“Standard configuration for soft-touch keys”](#)). Restore the user code setting on S1, see [addressing table](#).

Programming for intercom call



General intercom: function allowing calls to one or more internal units identified by the same call address as used by the external unit.
Selective intercom: function allowing calls to one or more internal units identified by a dedicated call address (see [table B](#)) which is different from the one used by the external unit.
General and selective intercoms CANNOT be used together on the same riser.

Programming/deleting intercom address (selective intercom only)



Take note of the S2, S1 setting and restore it when programming is complete

1)	2)	3)													
<p>Programming; set code, table B</p>	<p>S2 DIP</p> <table border="1"> <tr><td>1</td><td>2</td><td>3</td><td>4</td><td>5</td><td>6</td></tr> <tr><td>0</td><td>0</td><td>0</td><td>1</td><td>1</td><td>1</td></tr> </table>	1	2	3	4	5	6	0	0	0	1	1	1		<p>✓ OK Prog.</p> <p>x4</p>
1	2	3	4	5	6										
0	0	0	1	1	1										
<p>Cancellation</p> <p>DIP ON</p>	<p>S2 DIP</p> <table border="1"> <tr><td>1</td><td>2</td><td>3</td><td>4</td><td>5</td><td>6</td></tr> <tr><td>1</td><td>1</td><td>1</td><td>1</td><td>1</td><td>1</td></tr> </table>	1	2	3	4	5	6	1	1	1	1	1	1		<p>✗ KO Prog.</p> <p>x10</p>
1	2	3	4	5	6										
1	1	1	1	1	1										

Selective intercom addresses

You must set the intercom address on all the riser’s internal units.
 You can assign the same intercom address to a maximum of 3 internal units.
 For group calls, select the desired intercom codes simultaneously (max. 3).

TAB. B					
Code	DIP switch ON	S1	Code	DIP switch ON	S1
1	1		5	5	
2	2		6	6	
3	3		7	7	
4	4		8	8	

DIP-switch S2				DIP S1						
DIP 1	DIP 2	DIP 3	DIP 4	📞	🔑	1	2	3	4	👁
0	0	0	0							
1	0	0	0		🔑		INT	INTb		
0	1	0	0			INT	INTb			
1	1	0	0							
0	0	1	0							
1	0	1	0			INT			INTb	
0	1	1	0	📞						
1	1	1	0			INTb		INT		INT
0	0	0	1						INT	
1	0	0	1		🔑					
0	1	0	1						INT	
1	1	0	1							
0	0	1	1				INT			INTb
1	0	1	1			INT	INT	INT	INT	INT
0	1	1	1							
1	1	1	1							
				PROG						

ADDRESS

ON									
	1	2	3	4	5	6	7	8	

Example 1 - all systems (INCLUDING KITS!) - General intercom

on a monitor with user code 5, P2 programming = general internal call, P3 = general intercom with address 9

Example 2 - Selective intercom

on a monitor with user code 1 and intercom address 1, P2 programming = selective intercom with address 2, P3 = selective intercom with address 3

- Set S2 DIP switches 6 to the combination 1.
 - the privacy LED 👁 flashes.

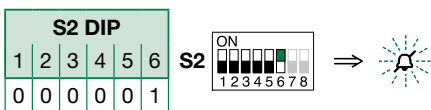

- Refer to the table **“Programming buttons for intercom call”** and select a combination in which the intercom function (either INT or INTb) is listed for the buttons you wish to program.

EXAMPLE 1: for P2= general internal call, set S2 DIP switches 1-2-3-4 to the combination 1000 or 0011 or 1011 (P2=INT) or 0100 (P2=INTb) and set S1 with address 5 as per **addressing table**, then go to point 3

EXAMPLE 1: for P3= general intercom, set S2 DIP switches 1-2-3-4 to the combination 1110 or 1011 (P3=INT) or 1000 (P3=INTb) and set S1 with address 9 as per **addressing table**, then go to point 3

EXAMPLE 2: for P2= selective intercom, set S2 DIP switches 1-2-3-4 to the combination 1000 or 0011 or 1011 (P2=INT) and set S1 with address 2 as **table B**, then go to point 3



EXAMPLE 2: for P3= selective intercom, set S2 DIP switches 1-2-3-4 to the combination 1110 or 1011 (P3=INT) and set S1 with address 3 as **table B**, then go to point 3.
- Press and release the key to be associated with the function
 - the lock-release LED 🔑 flashes 4 times.
 - a confirmation tone will sound.
- To exit programming mode, set S2 DIP switches 5-6 to the combination 00
 - the privacy LED 👁 switches off
- When programming is complete, set S2 DIP switches 1-2-3-4 to the combination 1111. Restore the user code setting on S1, see **addressing table**.

Allows direct programming of intercom call via the internal units.

✓ Requires 2 operators

Step 1: enter programming mode

Operator 1 and Operator 2 carry out the following procedures on 2 internal units:

1. Set S2 DIP switches 1-2 -3-4 to the combination 1111
2. Press the Key  and Self-ignition button  for 2 seconds.
 - » The internal unit emits 1 tone.
 - » The privacy LED  flashes.
 - » The audio button LED lights up.
 - » The internal unit enters audio mode.
 - » At this point the 2 operators will be communicating with each other.

Step 2: intercom call programming



Operator 1:

- ▶ Press the key you want to program to call operator 2 (e.g. 2).
 - » The internal unit manned by operator 1 emits a confirmation tone.

Operator 2:

- ▶ Press the key you want to program to call operator 1 (e.g. 1).
 - » The internal unit manned by operator 2 emits a confirmation tone.

Operator 1/ Operator 2:

- ▶ Press the audio key .
 - » The audio button LED  goes OFF.
 - » Programming of the 2 internal units is now complete.

To program another internal unit, move on to STEP 3.

Step 3: programming other internal units

Operator 1/ Operator 2:

1. Once the new station has been reached, carry out step 1 to begin communication
2. Repeat step 2



NOTE If a call is received during programming, it must be answered and the programming procedure resumed afterwards.

Programming keys for generic or coded actuator

DIP-switch S2											DIP S1
DIP 1	DIP 2	DIP 3	DIP 4	☎	⏏	1	2	3	4	👁	
0	0	0	0	☎	⏏		ACT				
1	0	0	0			ACT					
0	1	0	0						ACT		
1	1	0	0			ACT					
0	0	1	0		ACT	ACT	ACT	ACT	ACT	ACT	
1	0	1	0							ACT	
0	1	1	0		⏏						
1	1	1	0								
0	0	0	1								
1	0	0	1								
0	1	0	1					ACT			
1	1	0	1						ACT		
0	0	1	1					ACT			
1	0	1	1								
0	1	1	1								
1	1	1	1								
PROG											

ADDRESS

ON	□	□	□	□	□	□	□	
	1	2	3	4	5	6	7	8

Example:

on a monitor with user code 5, P1 programming = generic actuator, 👁 = coded actuator (code 125)



Take note of the DIP-switch settings

- Set S2 DIP switches 6 to the combination 1.
 - the privacy LED ☎ flashes.

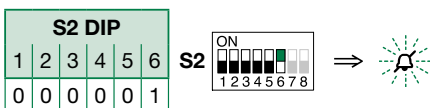

- Refer to the table **“Programming keys for generic or coded actuator”** select a combination in which the actuator function (ACT) is listed for the buttons you wish to program.
 - E.g.:** for P1= generic actuator, set S2 DIP switches 1-2-3-4 to the combination 1000 or 1100 or 0010 (P1=ACT), set S1 DIP switches to the combination 11111111, then go to point 3.
 - E.g.:** for 👁 = coded actuator (code 125), set S2 DIP switches 1-2-3-4 to the combination 0010 or 1010 (👁 =ACT), set S1 with address 125 as per [addressing table](#), then go to point 3.
- Press and release the key to be associated with the function.
 - the lock-release LED ⏏ flashes 4 times.
 - a confirmation tone will sound.
- To exit programming mode, set S2 DIP switches 5-6 to the combination 00.
 - the privacy LED ☎ switches off.
- When programming is complete, set S2 DIP switches 1-2-3-4 to the combination 1111. Restore the user code setting on S1, see [addressing table](#).**

Programming buttons for other functions

DIP-switch S2				Programmable functions							DIP S1		
DIP 1	DIP 2	DIP 3	DIP 4			1	2	3	4		ADDRESS 1 2 3 4 5 6 7 8		
0	0	0	0			CCS		D	PAN	AI			
1	0	0	0							D		AI	
0	1	0	0							CCS		AI	
1	1	0	0				CCP	PAN	K	CCS			
0	0	1	0										
1	0	1	0				CCS	CCP					
0	1	1	0			AI	K	CCS	CCP	D			
1	1	1	0				AI		PAN				
0	0	0	1			CCS	D	AI		PAN			
1	0	0	1			K	PAN	CCP	AI	CCS			
0	1	0	1			CCP	PAN			K			
1	1	0	1			PAN	CCS	K		CCP			
0	0	1	1	D			AI						
1	0	1	1										
0	1	1	1	NULL	NULL	NULL	NULL	NULL	NULL	NULL			
1	1	1	1	PROG									

Example:

on a monitor with user code 5, P4 programming = self-ignition, P1 = Doctor.

- Set S2 DIP switches 6 to the combination 1.

» the privacy LED flashes.

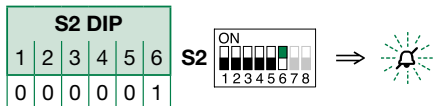

- Refer to the table **“Programming buttons for other functions”** and select a combination in which the desired/necessary functions are listed for the buttons you wish to program.

E.g.: for P4= self-ignition, P1 = Doctor, set S2 DIP switches 1-2-3-4 to the combination 0011 (P4=AI, P1=D).

- Press and release the keys to which you wish to assign the functions

» the lock-release LED flashes 4 times.

» one confirmation tone is emitted.

- To exit programming mode, set S2 DIP switches 5-6 to the combination 00

» the privacy LED switches off.

- When programming is complete, set S2 DIP switches 1-2-3-4 to the combination 1111.

Programming range



Take note of the S2, S1 setting and restore it when programming is complete

► Carry out steps 1 to 4

	1)	2)	3)	4)												
Range minimum address	<p>S1</p> <p>set code, addressing table</p>	<p>S2 DIP</p> <table border="1"> <tr><td>1</td><td>2</td><td>3</td><td>4</td><td>5</td><td>6</td></tr> <tr><td>0</td><td>0</td><td>0</td><td>0</td><td>1</td><td>0</td></tr> </table> <p>S2</p> <p>↓</p>	1	2	3	4	5	6	0	0	0	0	1	0		<p>OK Prog.</p> <p>x4</p> <p>KO Prog.</p> <p>x10</p> <p>S2</p> <p>↓</p>
1			2	3	4	5	6									
0	0	0	0	1	0											
Range maximum address																
Enable range																
Disable range																
Deleting the range	<p>DIP ON</p> <p>S1</p> <p>↑</p>	<p>S2 DIP</p> <table border="1"> <tr><td>1</td><td>2</td><td>3</td><td>4</td><td>5</td><td>6</td></tr> <tr><td>1</td><td>1</td><td>1</td><td>1</td><td>1</td><td>0</td></tr> </table> <p>S2</p> <p>↓</p>	1	2	3	4	5	6	1	1	1	1	1	0		
1	2	3	4	5	6											
1	1	1	1	1	0											

LED/alarm/lock-release/actuator programming



Take note of the S2, S1 setting and restore on completion of programming

► Carry out steps 1 to 4

	1)	2)	3)	4)
Input IN 1- IN 2 ⇒ LED (default)*				
Input CFP2 - IN 1 ⇒ ALARM*		 		
Input CFP2 - IN 1 ⇒ LOCK-RELEASE*				
Input CFP2 - IN 1 ⇒ CODED ACTUATOR*	 set code, addressing table	 		
Input CFP2 - IN 1 ⇒ GENERIC ACTUATOR*	DIP ON 			

* See "[Connections](#)".

Changing monitor ringtones

1. Keep the button pressed until a confirmation tone is emitted (this operation is only possible with the system in stand-by; otherwise the signalling LED will flash to warn the user)
2. Press and release the button:
 - once** (1 confirmation tone is emitted) to change the ringtone of calls from the external unit.
 - twice** (2 confirmation tones are emitted) to change the ringtone for calls from the switchboard.
 - 3 times** (3 confirmation tones are emitted) to change the ringtone for intercom calls made from the internal unit.
 - 4 times** (4 confirmation tones are emitted) to change the floor door (“CFP”) call ringtone.
 Any further pressing of the repeats the sequence described above.
3. Press and release button 1 to scroll through the various available ringtones in sequence.
4. Press button 2 to confirm selection of the last ringtone heard and to exit (at any time) the monitor ringtone change mode. On exiting the monitor ringtone selection mode a confirmation tone will be emitted.

Programming reset

Factory settings:

- Button functions for the S2 DIP switch 1-2-3-4 combination;
- Intercom address absent;
- Range function and min./max. addresses absent;
- Ringtone reset.
- Input IN 1 - IN 2 > LED (default).
- Doctor, Privacy and Hands Free functions disabled.



Take note of the S2, S1 setting and restore on completion of programming

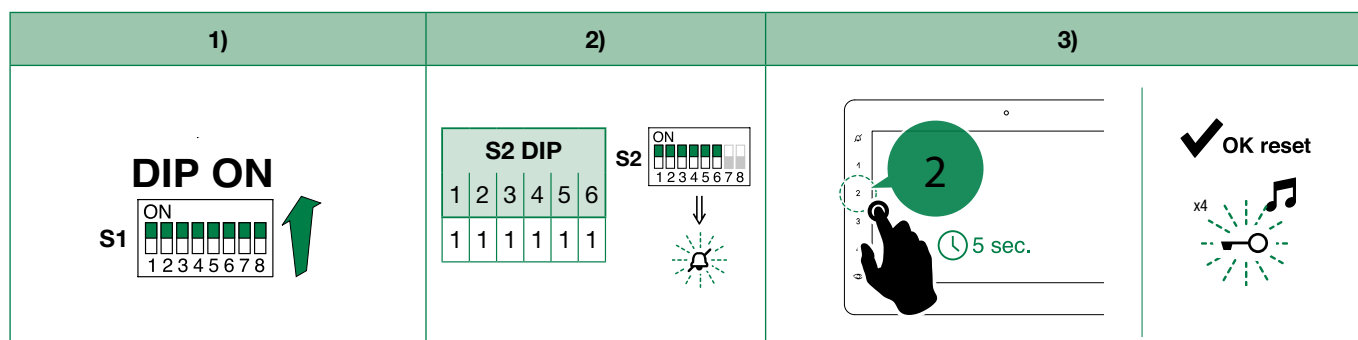

System performance and layouts

For further information of system performance and to view installation layouts, click on the type of system that best meets your needs:

- [Audio/video kit](#) for the creation of audio-video systems for *individual residences*
- [Building Kit audio/video system](#) for the creation of audio-video systems for *small apartment blocks*
- [SBTOP audio/video system](#) for the creation of audio-video systems for *residential complexes*.

CERTIFIED MANAGEMENT SYSTEMS



www.comelitgroup.com

Via Don Arrigoni, 5 - 24020 Rovetta (BG) - Italy

