

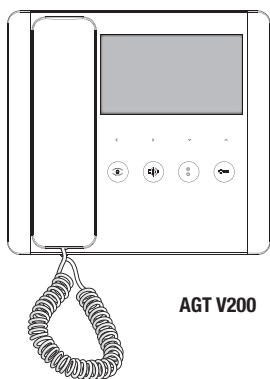

AGT KIT V200 + TARGHA

FA01427-EN



AGT V200

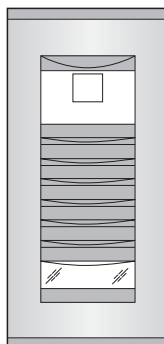

TARGHA 200

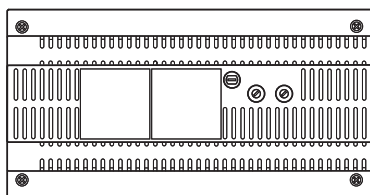

VA/200

INSTALLATION MANUAL AGTK200V03

CONTENTS OF THE KIT

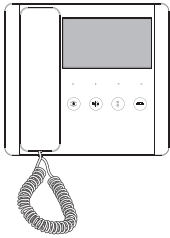

AGT A200

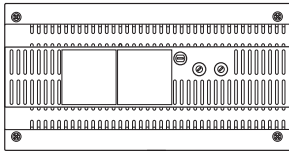

VA/200

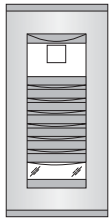

TARGHA 200

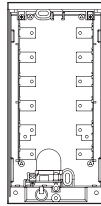

HBP

General precautions

- Read the instructions carefully before beginning the installation and carry out the procedures as specified by the manufacturer.
- The product must be installed, programmed, commissioned and serviced by qualified technicians, correctly trained with regard to respecting the regulations in force, including implementing accident-prevention measures.
- Before carrying out any cleaning or maintenance operation, disconnect the power supply.
- The equipment must only be used for the purpose for which it was designed.
- The manufacturer declines all liability for any damage as a result of improper, incorrect or unreasonable use.

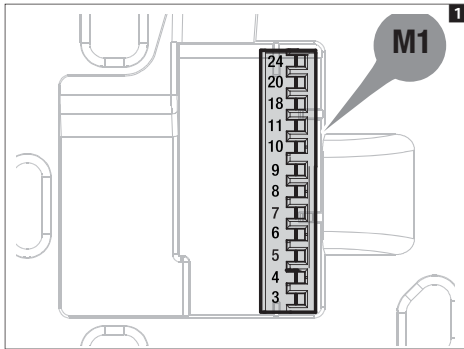
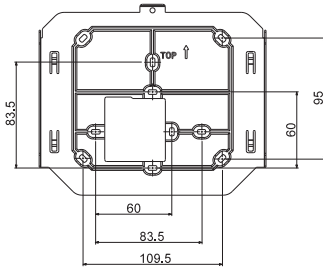
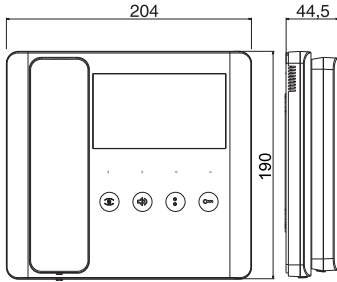

Technical data

Type	For all models
Power supply (VDC)	14 to 17.5
Current consumption (mA)	95
Consumption in stand-by mode (mA)	< 12
Single LED consumption (mA)	1
Bandwidth at -3dB (MHz)	5
Video input impedance (kΩ)	≥ 22
Coaxial video input (Vpp)	1

AGT V200

Description of AGT V200

Internal video receiver.

Function of terminals and jumper

Terminal board M1



-  3 Video signal
 -  4 Video signal screen
- Coaxial cable



If the line does not continue, connect a 75Ω resistor (violet-green-black-gold) between terminals 3 and 4.

-  3 Positive video signal
 -  4 Negative video signal
- Twisted-pair cable

If the line does not continue, connect a 56Ω resistor (green-blue-black-gold) between terminals 3 and 5 and a second 56Ω resistor between terminals 4 and 5.

-  5 -
 -  6 +
- 14 to 17.5 V monitor power supply

-  7 Call from entry panel input
-  8 Audio to monitor
-  9 Audio to entry panel

-  10
 -  11
- AUX2: auxiliary services (24V 100 mA)

-  18 AUX1 command (intercom stair light)

-  20 Doorbell input

-  24 AUX2 LED (active to earth)

Type	For all models
Video input from twisted-pair cable (Vpp)	±0.6
Storage temperature (°C)	-25 to +70
Operating temperature (°C)	+5 to +40
IP Rating	IP30
Video standard	PAL/NTSC
LCD TFT display (inches)	5

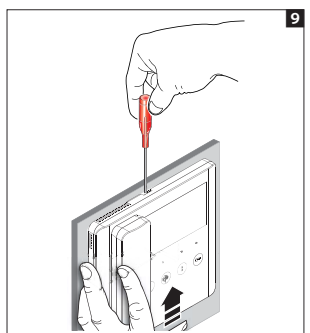
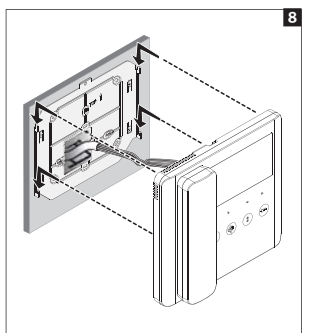
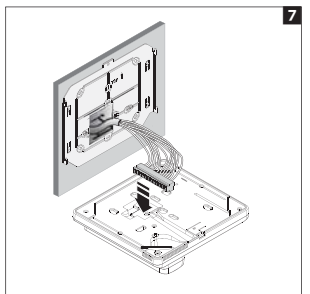
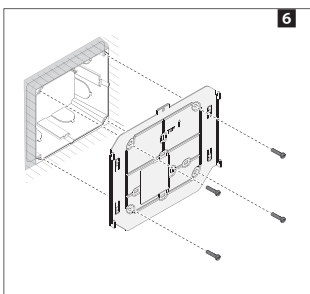
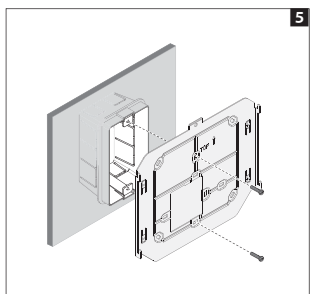
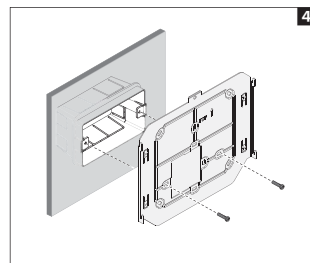
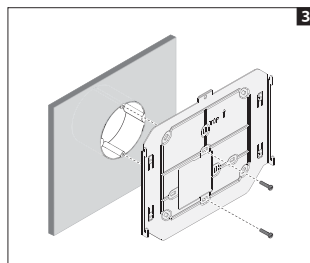
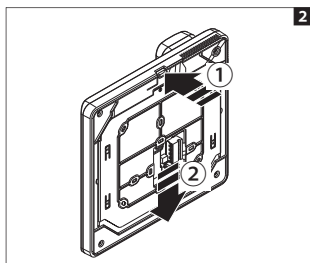

Installation

- Detach the video receiver from the metal support by pressing the plastic button and sliding the device smoothly off the support **2**.
- Fix the wall support to the round Ø 60 mm recessed box **3**, to the rectangular box 503 **4 5**, or to the Ophera (PHI) recessed box **6**, with the "TOP" arrow pointing upwards.
- Avoid overtightening the screws.
- To make the support more stable, use screws and expansion plugs.
- The box must be installed at a suitable height for the user.
- Once the connections have been made, attach the video receiver to the metal support **7 8**.
- To unhook the video receiver from the metal support, press the plastic tab and lift up the terminal **9**.

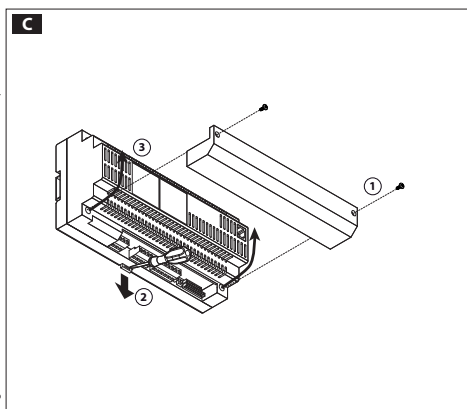
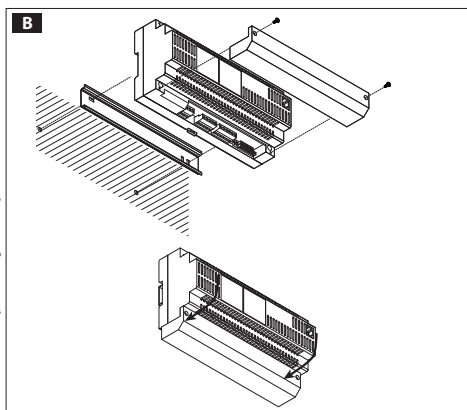
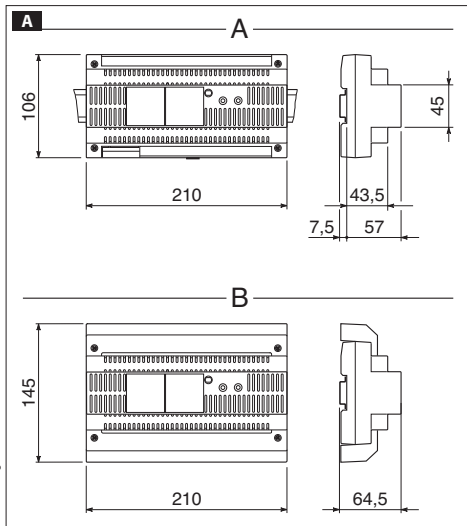

VA/200

Installation

The power supplier must ALWAYS be installed horizontally. The device can be installed on a DIN rail (EN 50022) in an appropriate electric panel or it may be wall-mounted using the protective terminal covers.

For disassembly, proceed as shown in figure **B** and **C**.

For the overall dimensions see figure **A**.

NOTE. Proper ventilation is required if the power supplier is installed in a metal container.

Technical data

Type	VA/200
Nominal voltage (V AC)	230
Rated power max (VA)	60
Dimensions (DIN)	12
Storage temperature (°C)	-25 ÷ +70
Operating temperature (°C)	0 ÷ +35
IP Rating (IP)	30

Entry panel, internal extension and accessories power supply

Nominal voltage (V DC)	17.5
Max continuous operating current (intermittent)(A)	0.9 (1.5)

Audio entry control accessories power supply

Nominal voltage (V DC)	12
Max continuous operating current (A)	0.4

Solenoid door lock power supply

Nominal voltage (V DC)	12
Max intermittent operating current (A)	0,5

OPERATING CHARACTERISTICS

System activation timer

The installation remains active for 30 s following a call at the entry panel. If the handset is lifted during this interval, the activation time is increased by 30 s and may be extended to a maximum of 90 s. by adjusting potentiometer **TV**, figure **D**, pag. 5.

If the system is activated by the entry panel button, located on the internal unit, the system activation time (when not interrupted by another call) may be adjusted between 30 and 90 s using potentiometer **TV** in figure **D**, pag. 5.

System deactivation

The installation is switched off by the system timer once the set time has elapsed, or on completion of the electrical door lock function.

Call note

The unit is equipped with two differential call tone generators.

The first generator (terminal 8, terminal board B) is activated each time a call is made at the entry panel which simultaneously causes the system activation timers to switch on.

The second generator (terminal 8A, terminal board B, and jumper **SW** in figure **D**, pag. 5, energised) activates without switching on the system. This means that the second generator may be used as a landing call signal.

When jumper **SW** is de-energised, the activation of the second generator causes the system to switch on, and permits, if required, the identification of two call sources (2 entry panels).

The outputs of the two call generators can simultaneously control a maximum of 3 internal units.

Door lock release (12V 1A)

The supply voltage to the electrical door lock is limited to approximately 1 to 15 s (adjusted using the potentiometer --- in figure **D**, pag. 5) also with continuous activation of the door lock release button on the internal unit.

If the door lock release is activated by an auxiliary button (connected to terminal 23), the electrical door lock is energised for the duration of activation of the said button.

Conversation privacy









The unit powers audio and video conversation privacy when the monitors and handsets are installed in the same system.

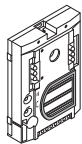
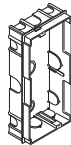
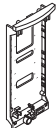



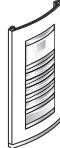

Stair light control

The stair light command can be performed with the monitor on (button Aux1), using the unit-relay VLS/101 connected to terminal 22 of the VA/200.

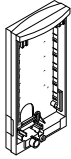

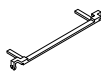

TARGHA 200

COMPONENTS

HAVC/200		Audio-video module HAVC/200
HTS		Embedding box
		Chassis
		Cable guide joints
		Spacer
		Screws
	HPV/1	
		Micro-contact
		Lighting module
		Cable-clamp plate

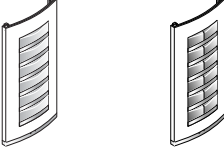
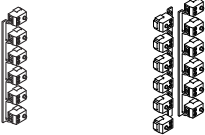
HBP		Surface housing
		Hole plugs
		Cable guide joint
		Joint
		Screws and anchors
KHPS		Button
		Micro-contact
		Button spring

ADDITIONAL PUSH-BUTTON PANEL

HPP/6 HPP/12D		Plate
		Micro-contacts with common call
		Lighting module
		Cable-clamp plates
		Hole plug

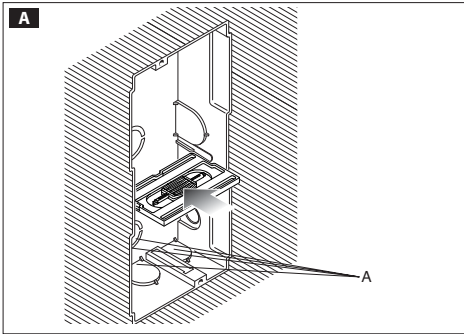

Recessed installation

The embedding box HTS must be fitted flush with the wall at an appropriate height.

In the case of video entry panels, the height should be such as to exploit the features of the camera to the full.

Fit the spacer into embedding boxes to avoid deformation **A**.

Insert the audio-video module at the top, near to the top moulding of the chassis **B**. In those installations liable to be affected by the Larsen effect, the microphone can be fitted in a remote position, as indicated in figure **B**. Apply the micro-contact (bottom right) in the relevant seat **C**. Insert the lighting module in the relevant seat **D**.

Remove the two plugs protecting the threaded holes in the embedding box and secure the chassis using the two screws supplied **E**.

Perform the wiring and secure the wires in place using the cable-clamp plate **E**.

An additional pushbutton can be installed on the front plate: follow the instructions supplied with the actual button for its assembly.

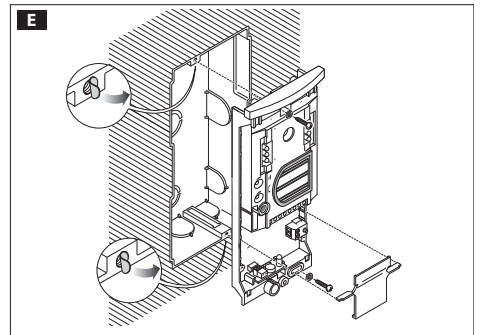
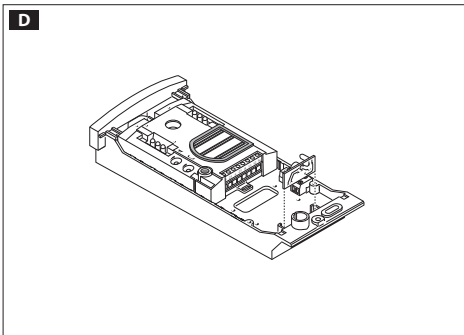
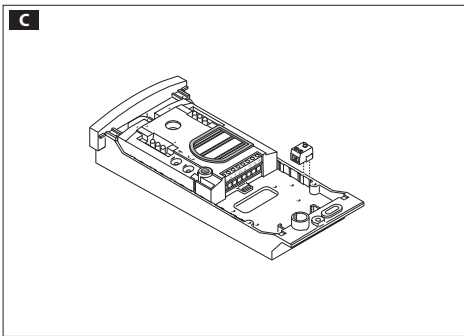
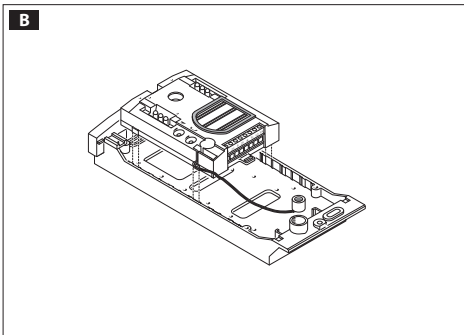

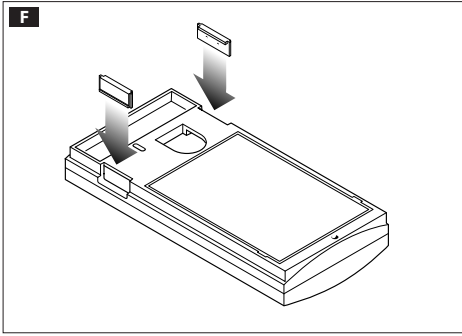

Wall mounting

Apply the two hole plugs at the base **F**.

Fit the embedding box HBP (3-module or round Ø 65mm version) flush with the wall at an appropriate height.

In the case of video entry panels, the height should be such as to exploit the features of the camera to the full.

Fasten the base onto the wall using the screws and screw anchors supplied **G**.

Insert the audio-video module at the top, near to the top moulding of the base **H**.

In those installations liable to be affected by the Larsen effect, the microphone can be fitted in a remote position, as indicated in figure **H**.

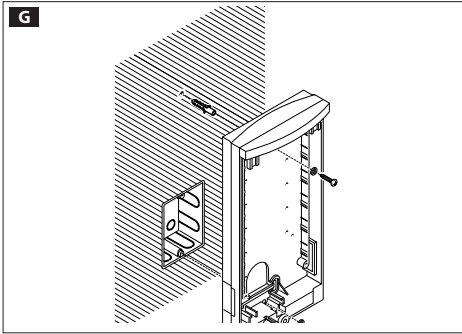

Apply the micro-contact (bottom right) in the relevant seat **I**.

Insert the lighting module in the relevant seat **J**.

Perform the wiring and secure the wires in place using the cable-clamp plate **J**. An additional pushbutton can be installed on the front plate: follow the instructions supplied with the actual button for its assembly.

Assembly of the button

The name card can be removed and filled in with the relevant information by removing the card clip followed by the actual card itself **K**. Personalized name cards can be used up to a maximum of 2 mm thick.

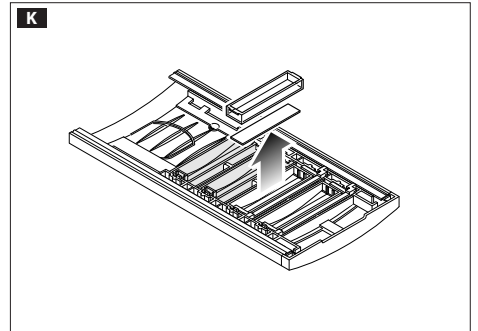
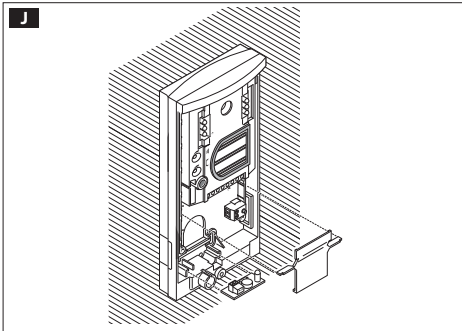
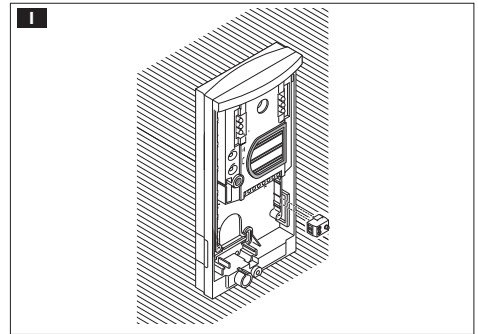
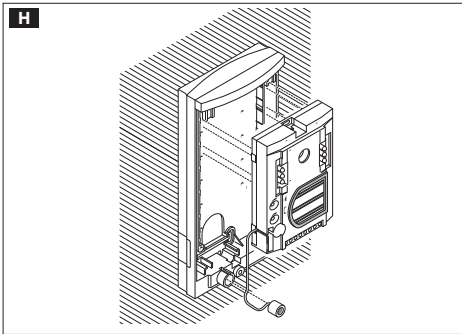

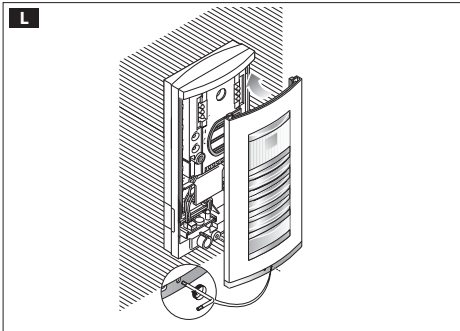

Closure of the cover plate

In order to fit the front plate, first insert the upper part in the top moulding and then, using a Allenkey s 2.5, tighten the lock screw **L M**.

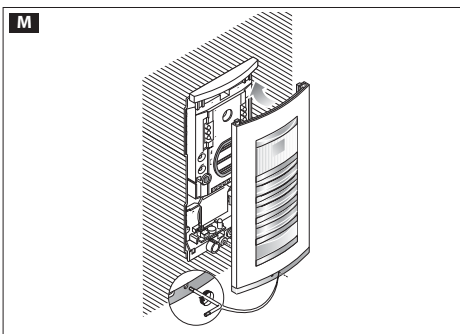

Side-by-side recessed installation

For horizontal **N O** or vertical **P Q** combinations, remove the hole plugs and insert the cable guide joints. Fit the spacer into embedding boxes to avoid deformation **O Q**.

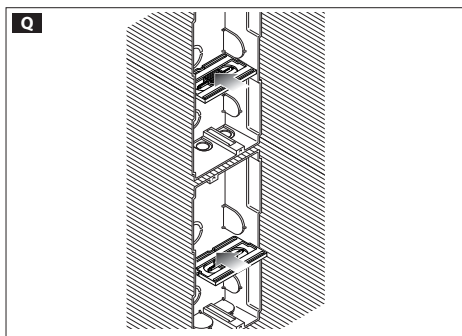
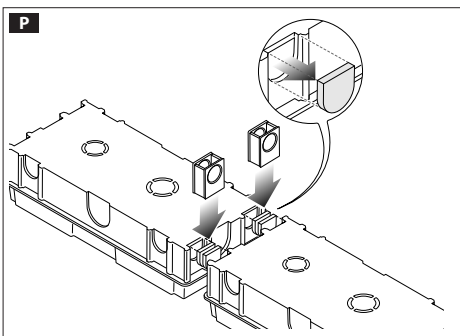
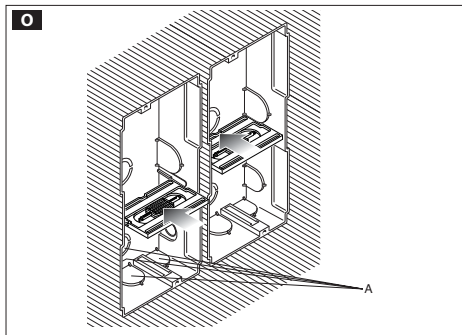
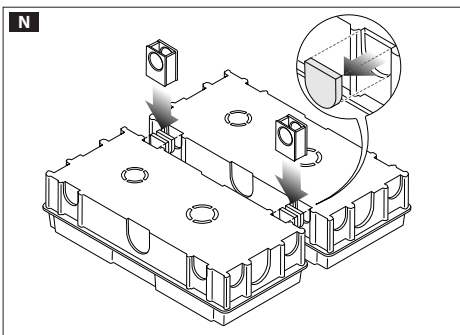

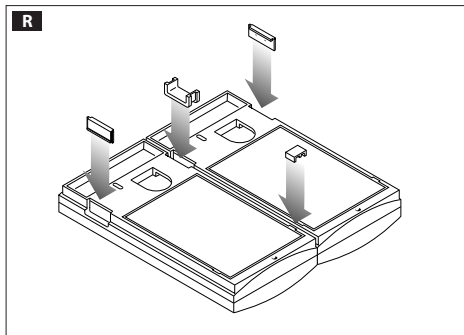

Side-by-side wall installation

For horizontal combinations, insert the two hole plugs on the outside, at the bottom inside the cable guide joint and top inside the joint **R**.

Fasten the bases to the wall using the screws and screw anchors supplied **S**.

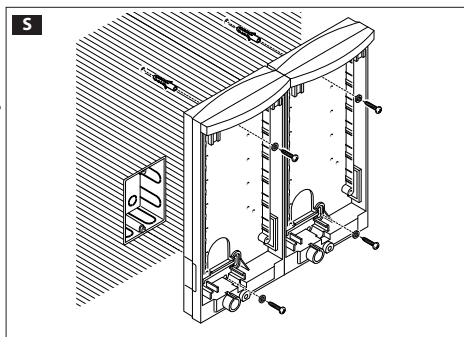

Terminal function

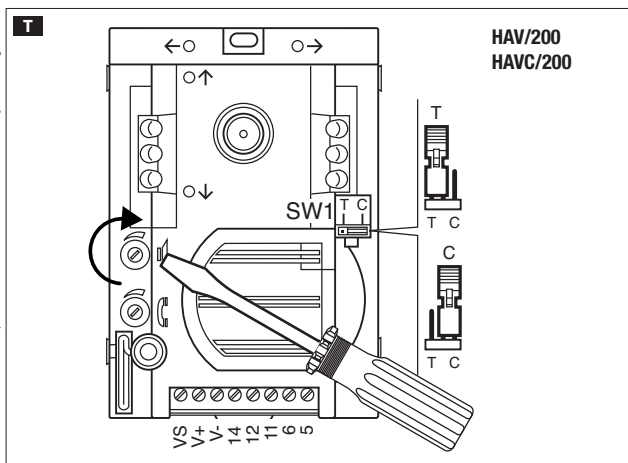

Terminal boards

- 5 - Supply voltage
- 6 + 14 ÷ 17,5 VDC
- 11 audio to receiver
- 12 audio from receiver
- 14 enabling
- V- negative video signal
- V+ positive video signal
- V+ video signal
- VS video signal shield

(1) Terminals for use when the video signal is transmitted via twisted pair.

(2) Terminals for use when the video signal is transmitted via coaxial cable.

Adjustments

	loudspeaker audio
	microphone audio

SW1 (video transmission type)

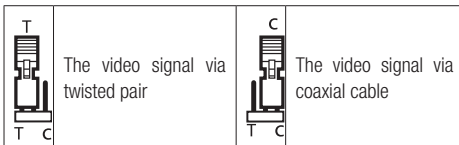

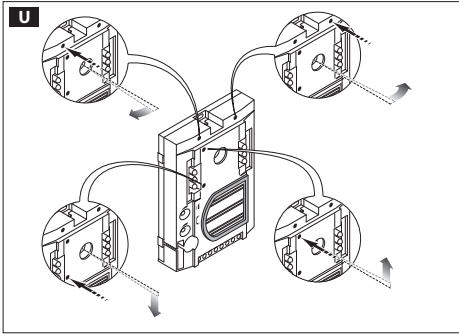

Orientation of the camera

CCD colour camera which can be rotated manually both horizontally and vertically by $\pm 11^\circ$ **U**, with fixed-focus lens (see **V** for the dimensions of the field of view) and phonic group (the microphone can be removed and fitted in a remote position where the installation features so require).

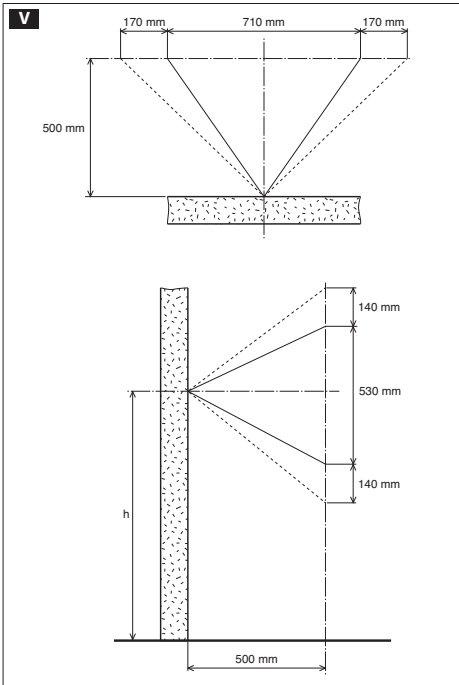

Technical data

Type	HAVC/200
Power supply (V DC)	14-17,5
Absorption (mA)	250
Sensor CCD	1/4"
Video output composite 1 Vpp (Ω)	75
Resolution (lines)	380
Lens fixed-focus	f 3,7 F 5 (pin-hole)
Storage temperature ($^\circ\text{C}$)	-25 +70
Operating temperature ($^\circ\text{C}$)	-15 +50
IP Rating (IP)	54
Standard video	PAL
Resolution (pixel)	680x512
Minimum lighting (LUX)	5

The product complies with the relevant directives in force.

Dismantling and disposal. Dispose of the packaging and the device responsibly at the end of its life cycle, in compliance with the laws in force in the country where the product is used. The recyclable components are marked with a symbol and the material ID marker.

THE DATA AND INFORMATION IN THIS MANUAL ARE SUBJECT TO CHANGE AT ANY TIME AND WITHOUT ANY ADVANCE WARNING. UNLESS OTHERWISE INDICATED, MEASUREMENTS ARE GIVEN IN MILLIMETRES.

CAME 
BPT

CAME.COM

CAME S.P.A.

Via Martiri Della Libertà, 15
31030 Dosson di Casier - Treviso - Italy
tel. (+39) 0422 4940 - fax. (+39) 0422 4941